

Top Load Case Packers

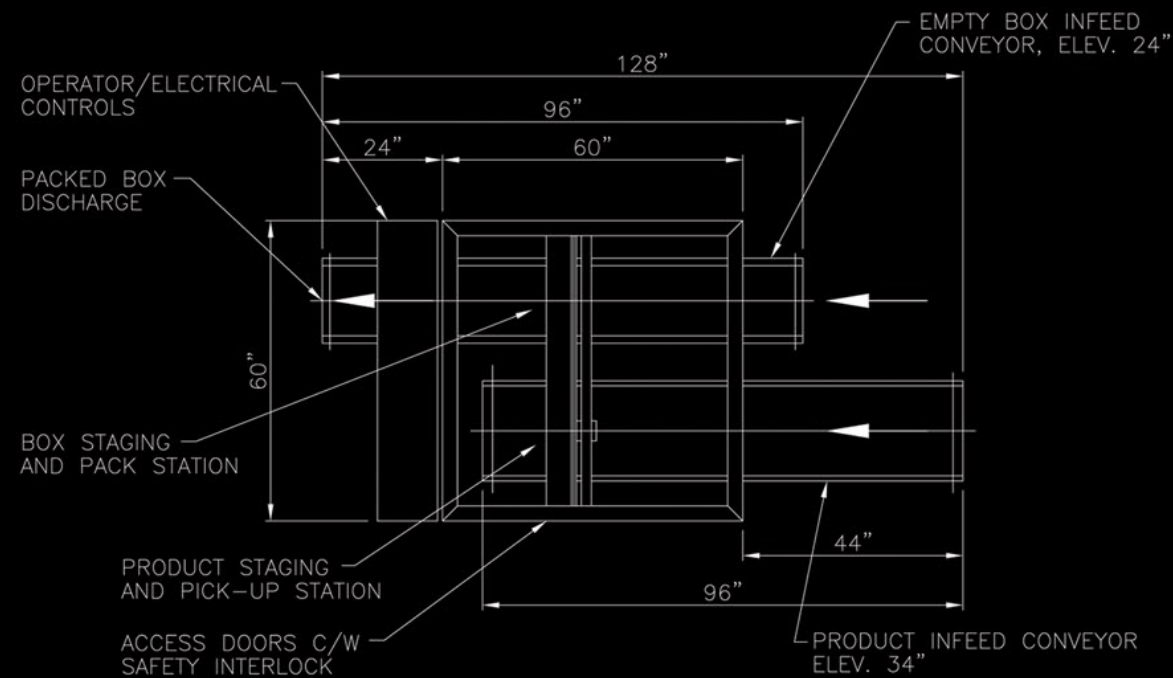

Features:

- Heavy duty fabricated base frame of structural stainless steel tube
- Clear anodizing of all manufactured aluminum components
- Stainless steel guarding, shafts and contact parts
- Includes the latest servo technology
- HMI touch screen technology
- High performance gear belts, pulleys and slider rails
- Smooth, quiet and care-free operation
- Quick change mechanical and vacuum end effectors
- Active box flap conditioning
- Rapid changeover components including hand wheels, cranks handles, detent pins and ratchet handles



Top Load Case Packers can be used for a wide range of applications in most industries including:

- Food and Beverage
- Confections
- Pharmaceutical
- Household and Industrial
- Product Manufacturers
- Automotive
- Dairy
- Meat and Poultry



50 Centennial Road, Orangeville, Ontario L9W 3T4
Telephone: 519-942-2442 Fax: 519-942-0886
www.trinamics.com

Top Load Case Packers



TRE100TL, TR1000TL & TR2000TL

Trinamics Top Load Case Packers provide a tremendous degree of flexibility within a very compact footprint. The user friendly nature facilitates packing a large variety of products across a broad range of applications. Solutions are available for low to high speed requirements.

Both the high speed TR1000TL / TR2000TL and the lower speed TRE100TL Top Load Case Packers include standard features such as multi-axis servo control and field adjustable motion profiles. The use of other standard features such as quick changeover components, selectable presets and operator friendly servo "teach" functions through the HMI increase "up time", line efficiencies and line productivity.



Top Load Case Packers



Rugged Construction

The heavy duty fabricated base frame of structural steel tubing ensures rigidity, stability and durability. The attractive stainless steel finish can be “refreshed” at any time even when used in a challenging environment.

Flap Guides

Positive flap control of both major and minor flaps ensure products are transferred from the staging area to the waiting case in a repeatable and controlled fashion.

High Precision Timing Belts and Pulleys

Reinforced polyurethane timing belts used to transfer drive forces to mechanical components ensure reliability, repeatability, and care free operation over the long term. Belt stretch after installation is virtually eliminated.



Rapid Three-Dimensional Changeovers

The extensive use of hand wheels and quick change components on adjustment points facilitates rapid three dimensional changes.

Servo Driven Multi Axis Control

Highly flexible multi-axis servo powered control provides precise speed and positional control as well as offering reliability and repeatability. The inherent flexibility of servos leave many options open for future considerations.

Infeed Conveyor

Trinamics tailors a variety of product conveyors and handling systems to ensure full control when transferring product into the case packer.



User Friendly HMI Control Station

The operator control panel features a full color alphanumeric touch-screen display (see options). System diagnostics and operational status are instantly available to operational/maintenance personnel.

Profitability & Efficiency

The use of standardized control features such as rapid changeovers, adjustable “save” functions and touch screen selectable preset recalls increase efficiency, productivity and profitability.

Precision Slides

Precision hardened slides allow for higher travel rates with lower levels of vibration, noise and resistance. Hardened slides require less maintenance over time than roller or contoured roller-rail style slides.

Fully Interlocked Guarding

Fully interlocked doors of clear polycarbonate provide quick access to the product run for operational convenience while removable stainless steel panels provide secured access for maintenance and service personnel.



Electrical Panel Enclosures

The NEMA 12 electrical control cabinet includes a fused electrical disconnect as standard equipment. High voltage wiring is separated from low voltage wiring and all terminations are clearly labeled. Options include NEMA 4X cabinet and a variety of components to suit any build specification.

Clean & Accessible Design

The open design of the case packer is user-friendly and easily accessed by operators and maintenance personnel. Safety interlocked clear polycarbonate doors ensure safety.

Localized or Central Vacuum

Local Venturi style vacuum effectors provide spontaneous and stable vacuum when and where required. Other available options include rotary vane, regenerative blower and centralized vacuum.

